



OWNER'S / OPERATOR'S MANUAL



READ THIS MANUAL CAREFULLY!

It contains important safety information.

CX Series

48V Models:

X.2

CX.2

CX.2+2

CX.4+2

CXR.2

CXR.2+2

CXR.4+2

CXM.2

CXT.2

ALL RELEVANT XRT MODELS

INTRODUCTION

Congratulations on your purchase of your Drake vehicle. This manual contains information you will need for proper operation, maintenance and repair of your golf cart. A thorough understanding of these simple instructions will help you to obtain maximum enjoyment from your new Drake cart.

Drake vehicles are designed and built to provide the ultimate in performance and efficiency, however proper maintenance and repair are essential for achieving maximum functionality & enjoyment from your new Drake vehicle.

This manual provides detailed information for the maintenance and repair of the electric Drake vehicles, and should be thoroughly reviewed prior to servicing the vehicle. The procedures provided herein must be properly implemented, and the DANGER, WARNING, and CAUTION statements must be heeded.

This manual should be considered an essential accessory to your golf car and should remain with the car when borrowed to another individual or resold.

If you have any questions about the operation or maintenance of your golf cart, please consult a DRAKE dealer.

CX Series OWNER'S/OPERATOR'S MANUAL

© 2022 by Drake Golf Carts

All rights reserved. Any reprinting or unauthorized use without the written permission of Drake Golf Carts Company is expressly prohibited.

IMPORTANT MANUAL INFORMATION

Particularly important information is highlighted in this manual by the following symbols and notes. It is important to note that this information relates to specific safety issues, and must be read, understood, and heeded before proceeding with any operational or servicing procedures.



SAFETY ALERT SYMBOL

Used to alert you to potential personal injury hazards. Obey all safety messages that follow this alert to avoid possible injury or death.



WARNING

A WARNING alert indicates an immediate hazard that could result in severe personal injury or death – please heed.

CAUTION

A CAUTION alert indicates precautions that must be taken to avoid damage to the vehicle.

NOTE

A NOTE alert provides additional information to make procedures easier or clearer to understand.

NOTE

DRAKE continually seeks advancements in product design and quality; while this manual represents the most current information at the time of publication, there may be minor discrepancies between your golf car and this manual. If you have any questions concerning this manual, please consult your DRAKE dealer.

DRAKE reserves the right to change specifications and designs at any time without notice and without the obligation of making changes to units previously sold.



WARNING

Read and understand this manual completely before operating or servicing your golf car. This manual should be permanently with your golf car and should remain with the car when resold.

TABLE OF CONTENTS

IMPORTANT LABELS	1
SAFETY	2
OPERATOR SAFETY	2
SAFETY CONSIDERATIONS	2.1
MAINTENANCE REQUIRED FOR GOLF CAR SAFETY	2.2
SAFETY PRECAUTIONS DURING MAINTENANCE	2.3
BATTERY STORAGE AND CHARGING	2.4
CONTROLS	3
OPERATION PROCEDURES	4
PRE-OPERATION	4
OPERATION	4.1
MAINTENANCE	5
STORAGE	6
SPECIFICATIONS	7
WARRANTY	8

1 IMPORTANT LABELS



SAFETY AND INSTRUCTION LABELS



WARNING

Read the following labels carefully before operating your car and replace any labels that are damaged or have been removed. Ignoring these safety labels can result in severe personal injury or even death.

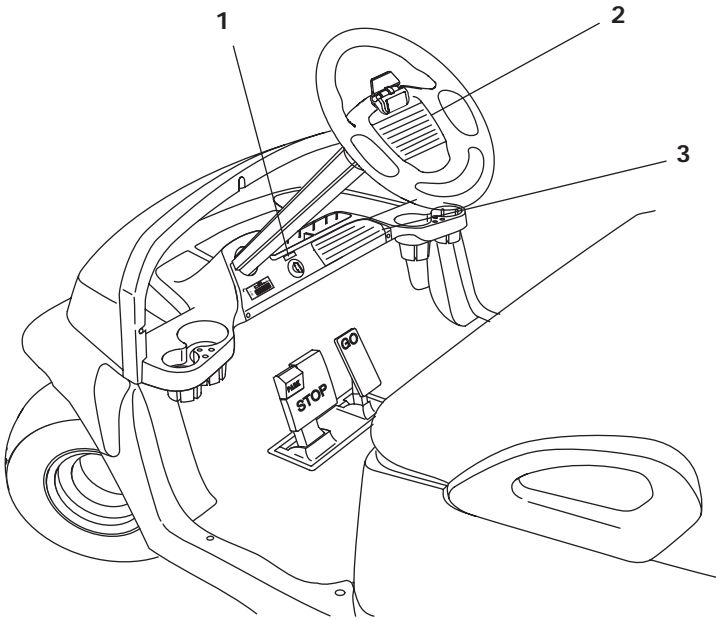

1



2

Operation Guide

- ◆ Press the accelerator pedal to start moving. To stop, release the accelerator and press the brake pedal
- ◆ Never travel at a speed too fast for the terrain, visibility, conditions or your experience. Drive with extra caution when operating the vehicle in reverse, in congested areas and when driving on wet, rough surfaces or slopes
- ◆ To park, press the brake pedal and push the park pedal, To release the parking brake, press the brake pedal to free the parking brake and then press the accelerator pedal to move.
- ◆ Only change between “Forward” and “Reverse” when the car is stationary.
- ◆ Do not press the accelerator pedal and the brake pedal simultaneously during operation.

3

WARNING

- ◆ Before using vehicle, read operating instructions.
- ◆ Use brakes to reduce speed.
- ◆ Drive slowly in turns and straight up and down slopes.
- ◆ Remain seated while moving.
- ◆ Never operate under the influence of alcohol or drugs.
- ◆ Two persons per seat maximum.
- ◆ Do not leave children unattended on vehicle.
- ◆ Do not start until all occupants are seated.

1 IMPORTANT LABELS

4



EXPLOSIVE GAS
Explosive gases are released when the batteries are charged or discharged. Keep area well ventilated. Keep sparks, flames, cigarettes and other sources of ignition away. Wear eye protection when working near batteries.



SULFURIC ACID
Sulfuric acid in batteries will burn skin, eyes and clothing. Keep batteries upright, and do not tip them. Keep vent caps tight and level. In event of injury, rinse with water and seek medical attention immediately.



ELECTRICAL SHORTS
Electrical shorts can result in burns, or battery explosions. Do not make a connection between positive & negative battery terminals, or between the positive terminal and the metal chassis.



NOTE

The configuration for label "4" is specific to models fitted with 6x flooded or AGM lead acid batteries. If you have any questions regarding the configuration of your vehicle please consult your nearest dealer.

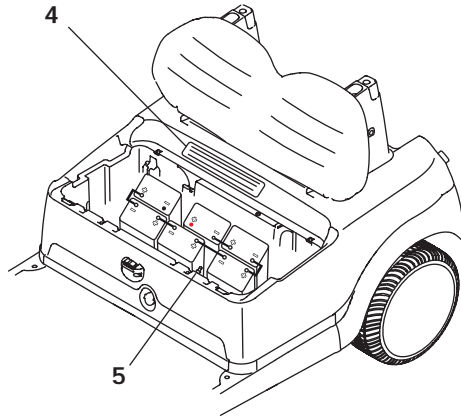

5 OFF | ON



SAFETY CONSIDERATIONS

Many vehicles are used for a variety of tasks beyond the original intended use of the vehicle. No warnings can take the place of good common sense and prudent driving practices.

PRE-OPERATION SAFETY

Read this Owner's/Operator's manual and observe all warnings and operation instruction labels affixed to the vehicle.

Perform the pre-operation checks found in Section 6 of this manual.

Only authorized people should drive the golf car, from the driver's side only, and only in designated areas.

Do not allow more than two occupants per seat.

Do not operate the golf car while under the influence of alcohol or drugs; their effect on vision and judgment make operating a golf car dangerous.

Do not operate the golf car on public streets, roads or highways unless allowed by law or local regulating authority.

DURING OPERATION

All persons must be seated. Keep entire body inside the vehicle and hold on while vehicle is in motion.

Avoid starting or stopping abruptly.

Reduce speed to compensate for poor terrain or conditions.

Apply service brake to control speed on steep gradients.

Reduce speed in wet areas.

Use extreme caution when approaching sharp or blind turns.

Use extreme caution when driving over loose terrain.

Use extreme caution in areas where pedestrians are present.

Do not make any modification or additions to the car which affects capacity or safe operation.

Do not run the engine indoors, engine and exhaust fumes are poisonous.



WARNING

The vehicle must come to a complete stop before engaging either the Forward or Reverse selector. Failure to do so will void the Warranty.

**SAFETY CONSIDERATIONS**

This section contains broad safety practices required for safe golf car operation. If you are responsible for the operation and maintenance of this golf car, we recommend you implement this golf car safety program.

Allow only authorized people to operate golf cars. It is recommended that only people who possess a valid motor vehicle driver's license be allowed to operate golf cars.

Place operation and safety instructions recommended by the golf car manufacturer, along with the golf course safety rules, in a highly visible place near the golf car rental area or golf car pick-up area.

It is also recommended that the following warnings be posted in a conspicuous location:

**WARNING**

Do not operate golf cars when under the influence of alcohol or drugs. Death or serious personal injury can result from failing to comply with the safety and warning instructions affixed to the golf car.

**WARNING**

Descend steep gradients slowly with foot on brake. Death or serious personal injury can result from failing to comply with the safety and warning instructions affixed to the golf car.

2.2 SAFETY



MAINTENANCE REQUIRED FOR GOLF CAR SAFETY

This section contains broad safety practices required for safe golf car operation. If you are responsible for the operation and maintenance of this golf car, we recommend you implement this golf car safety program.

Preventative Maintenance. Perform all scheduled maintenance in accordance with manufacturer's recommendations to provide the golfing patron with a safe, properly operating golf car.

Use insulated tools within the battery area to prevent sparks or battery explosion.

Use wheel blocks and support vehicle with jack stands. NEVER get below a vehicle that is supported by a jack.

Service the vehicle in an area away from open flame or sparks.

Keep complete records of the maintenance history of the vehicle.

Personnel. Allow only qualified, trained, and authorized personnel to inspect, adjust, and maintain golf cars.

Parts and Materials. Use only replacement parts and materials recommended by the manufacturer.

Ventilation. Always store gasoline vehicles in an area with good ventilation. Good ventilation prevents the accumulation of gasoline fumes within an enclosed area.

Never put fuel in a vehicle in an area that is subject to flame or spark. Pay particular attention to natural gas or propane water heaters and furnaces.

Never work around or operate a vehicle in an environment that does not allow ventilation of exhaust gases from the area. Carbon monoxide is a dangerous gas that can cause unconsciousness and is potentially lethal.



SAFETY PRECAUTIONS DURING MAINTENANCE

When performing maintenance, follow all safety instructions contained in the manufacturer's operation and service manuals, as well as the following safety procedures:

Properly immobilize golf car before beginning any maintenance to avoid any unexpected vehicle movement.

Properly lift & rest chassis before working underneath golf car to avoid any unexpected vehicle movement.

When working on the fuel system or the battery, do not smoke, or allow any sparks or open flames near the vehicle, to avoid any fires or explosions.

Before working on an electric golf car, disable the car's electrical system in accordance with the manufacturer's instructions to avoid electrical shock or damage to the electrical system.

Use only properly insulated tools when working on electrically powered golf cars or around batteries to avoid electrical shock or damage to the electrical system.

Maintain all safety devices including brakes, steering mechanisms, warning devices, and governors, in a safe operating condition. Do not modify these safety devices as supplied by the manufacturer.

After each maintenance or repair, the car must be driven by a qualified, trained, and authorized person – in an area free of pedestrian traffic – to ensure proper operation and adjustment.

Record all maintenance performed in a maintenance record log by date, name of person performing maintenance, and type of maintenance. Periodically inspect maintenance log to ensure accurate and complete entries.

Provide operator comment cards to assist in identifying non-periodic maintenance needs for specific golf cars.

Maintain in a legible condition all nameplates, warnings, and instructions provided by the manufacturer.

If new nameplates, warnings, or instructions are needed, contact your Drake Golf, Lifestyle and Commercial Carts Company dealer.

2.4 SAFETY



BATTERY CHARGING

The following precautions must be adhered to in order to ensure Maintenance worker safety.

Place Tow/Run switch in the TOW position before disconnecting or connecting the batteries. Failure to heed this warning could result in a battery explosion or severe personal injury.

To avoid unintentionally starting an electric vehicle, disconnect the batteries and discharge the controller.

Only use battery charging facilities and procedures that are in accordance with applicable ordinances and regulations to avoid explosions, electrical shock or damage to the electrical system.

Periodically inspect charging facilities and procedures to be certain that applicable safety codes, regulations, and procedures are being followed to avoid any fires or explosions.

Provide Protection from the Elements

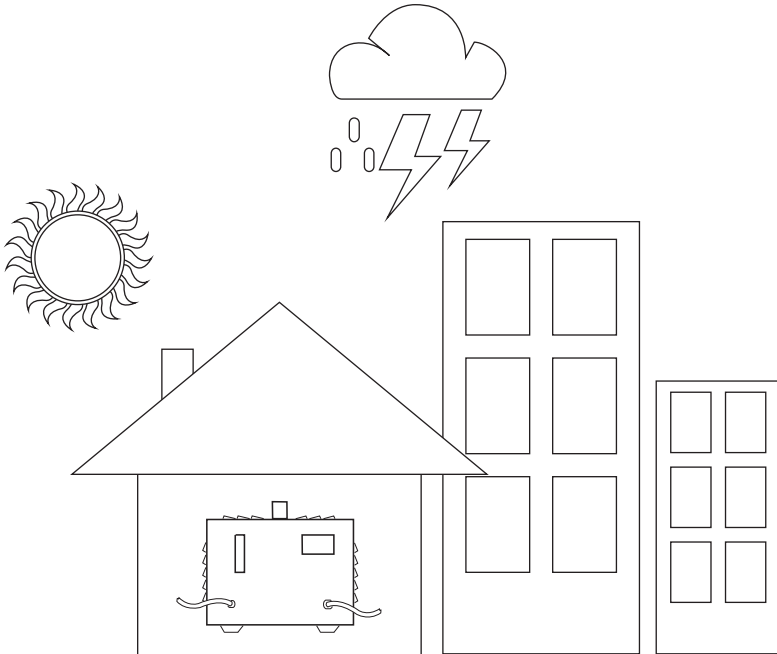

Do Not Block Airways



MAIN SWITCH

The main switch controls the following items:

“OFF”

All electrical control circuits are switched off. The golf car cannot be operated. The key can be removed only in this position.

“ON”

Electrical circuits are switched on. The golf car can be driven.



VOLTAGE INDICATOR

The voltage indicator displays how much charge is left in the batteries. When the batteries are at full charge, either all the LEDs will be lit or just a single LED bar at the top, nearest the “1” will be lit. As the battery capacity decreases, the LEDs will move down toward the “0” bar. When the LED light is lit on or up to the second bar from bottom, battery capacity is significantly low, and the batteries must be charged as soon as possible.

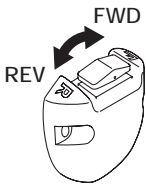

DRIVE SELECT SWITCH

The drive select switch is used to shift the golf car into FORWARD or REVERSE direction. ONLY after coming to a complete stop, toggle the switch to the desired position. When the Drive Select Switch is moved to the reverse “REV” position, the alarm will buzz. Middle position is NEUTRAL.

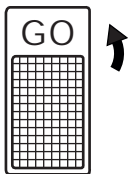

ACCELERATOR PEDAL

The accelerator pedal is on the right-hand side and is indicated by “GO” on the pedal. The accelerator pedal controls the speed of the cart. When depressed the speed will increase, when released the speed will decrease.



BRAKE PEDAL

The brake pedal is on the left hand side & indicated by the “STOP” on the pedal. Press down on the brake pedal to stop the car. The extent of the pressure used to press the brake will determine the responsiveness of the brakes, and the time taken till the car is stationary.

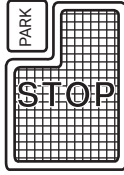
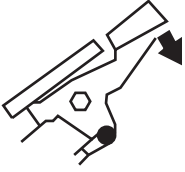

PARK PEDAL

The Park Pedal is indicated by the "PARK" on the top left of the brake pedal. Press down on the park pedal whenever car is stationary to lock the brakes.

NOTE

Disengage the parking brake by depressing the accelerator pedal.

NOTE

If your vehicle is equipped with a magnetic parking brake, there are several things you need to be aware of.



MAGNETIC PARKING BRAKE PEDAL

The brake pedal with a magnetic parking brake system does not have a parking pedal. The magnetic parking brake engages automatically when the vehicle comes to a complete stop.

When the vehicle is in motion, depress the brake pedal till the vehicle comes to a complete stop, the magnetic parking brake will engage automatically with a "click" sound. Once the magnetic brake is engaged the cart will be locked in a stationary position and cannot be moved until the magnetic brake is released.

The magnetic brake is disengaged by depressing the accelerator pedal.

If the vehicle's battery has been over-discharged, had a catastrophic battery or other failure and does not have the voltage required to disengage the magnetic brake, you may disengage the magnetic brake manually. See maintenance section for more information on how to disengage the magnetic brake manually.

⚠ WARNING

The parking brake will automatically disengage if the accelerator pedal is depressed. If the main switch is in the "ON" position, depressing the accelerator may suddenly cause the golf car to move. Death or serious personal injury can result from failing to comply with the safety instructions in this manual.

TOW SWITCH



TOW / MAINTENANCE  RUN

Before operating the car, make sure the tow switch is in the “RUN” position. Vehicles are equipped with a “Run-Tow/Maintenance” switch located underneath the seat on the front driver side. The “Tow/Maintenance” position allows the vehicle to roll freely without activating the warning beeper and eliminating potential damage to controller or motor.

With the switch in “TOW/MAINTENANCE” position:

- the controller is deactivated
- the electronic braking system is deactivated which allows the vehicle to be towed or roll freely
- the warning beeper is deactivated

NOTE

If the vehicle is equipped with a magnetic parking brake, the vehicle will not roll freely until the magnetic parking brake is manually disengaged. See maintenance section for more information on how to disengage the magnetic parking brake manually.



TOW  RUN

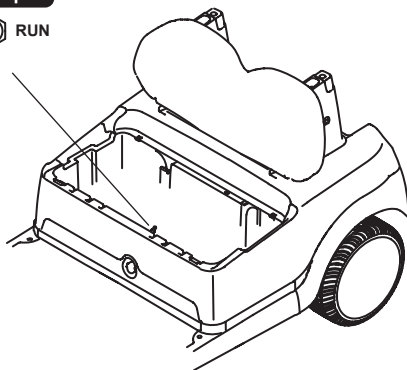
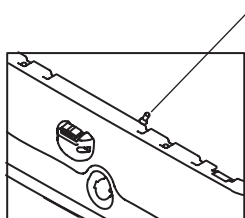

WARNING

Before attempting to tow vehicle, move the Run-Tow/Maintenance switch to the “Tow/Maintenance” position. Failure to do so will damage the controller or motor.

Before disconnecting or connecting a battery, or any other wiring, move the Run-Tow/Maintenance switch to the “Tow/Maintenance” position.

After connecting a battery, or any other wiring, wait a minimum of 30 seconds before moving the Run-Tow/Maintenance switch to the “Run” position.

3 CONTROLS

LITHIUM BATTERY

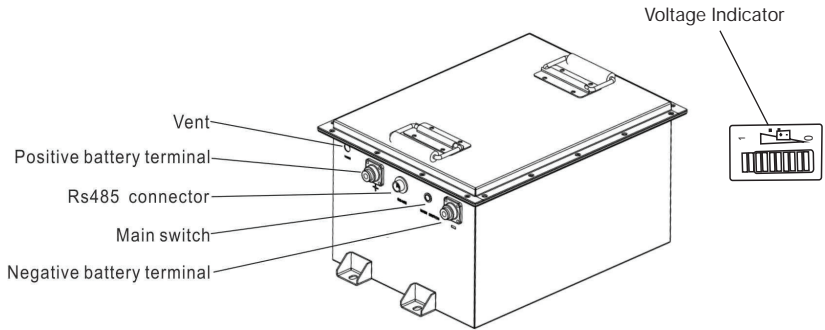

BATTERY MAIN SWITCH

Press the “Main switch” button to turn on the battery, an illuminated green light indicates that the battery is powered on. Press and hold the “Main switch” for 3 seconds or longer to turn of the battery.

OPERATION

1. Press the “Main switch” button to turn on the battery. Once the battery is on the terminals will be charged and current will flow through the vehicle’s system. The green light indicates power is on.
2. Once the battery is turned on, the meter will display the remaining battery power. There are ten bars in total and each bar represents 10%. When full charged all ten bars will be illuminated. When 20% charge remaining, only two bars will be illuminated.

WARNING

ALARM

During operation the alarm within the battery may sound for one of the following reasons:

1. When the voltage indicator reaches the remaining two bars, 20% remaining, the battery will sound an under-voltage alarm, indicating that the battery needs to be charged.
2. When the voltage indicator reaches the last remaining bar, 10% charge remaining, the battery will sound an under-voltage alarm, indicating that the battery needs to be charged urgently. It is advised to stop driving the cart immediately and charge the battery as soon as possible.

CAUTION

When the battery sounds the under-voltage alarm, stop driving the vehicle and charge the battery as soon as possible. If you do not heed the warning and continue to drive the vehicle, the battery will switch off causing the golf cart to suddenly stop. We are not responsible for any loss caused by the sudden stop whilst driving.

 **WARNING****AUTOMATIC SWITCH-OFF DUE TO UNDER-VOLTAGE**

The lithium battery will switch off due to under-voltage. There will be no power to the system, and the vehicle will not drive. All the electronic systems within the vehicle will be without power, rendering all accessories non-functional until power is restored to the battery by charging the vehicle at your nearest charging station.

If the vehicle is equipped with a magnetic parking brake:

- The magnetic parking brake will be engaged in park position and the rear wheels will not move. See the maintenance section for more information on how to manually disengage the magnetic parking brake.
- The vehicle may need to be towed to the nearest charging station, it is important to ensure the magnetic parking brake is disengaged, and the tow switch is in the "off" position.

 **WARNING****AUTOMATIC SWITCH-OFF**

The battery may switch off immediately whilst the cart is in motion due to over-temperature, over-current, under-voltage, or external short-circuit. You will be required to assess the vehicle's situation and the potential cause of the automatic switch-off. Some of the potential causes may be:

1. Too much current required by the vehicle due to a combination of high acceleration, high-load, and steep gradient.
2. High ambient temperature.
3. External short-circuit.
4. Fault within the battery pack.
5. Fault within the vehicle.

Contact your nearest dealer for additional support.

4 PRE-OPERATION PROCEDURES



OPERATOR SAFETY

Pre-operation checks should be made each time you use your golf car. Get into the habit of performing the following checks in the same way so that they become second nature.



WARNING

To keep car from moving while performing pre-operation checks: Remove main switch key. Apply parking brake. Death or serious personal injury can result from failing to comply with the safety instructions in this manual.

BATTERIES

Check that the batteries are held securely in place to prevent them from being damaged from vibration or jarring. Also check that no battery caps are missing to prevent battery acid from spilling from the batteries. Check the battery terminals for corrosion.



WARNING

Battery electrolyte is poisonous and dangerous, causing severe burns, etc. It contains sulphuric acid. Avoid contact with skin, eyes or clothing. Ventilate when charging or using in an enclosed space. Always shield your eyes when working near batteries. **KEEP OUT OF REACH OF CHILDREN.**

TYRES

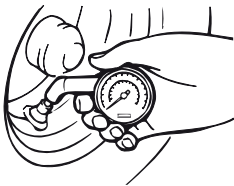

Air Pressure

Check the tyre air pressure before operating the golf car.

Tyre pressure: 172 kPa, 25 psi, 1.5 bar

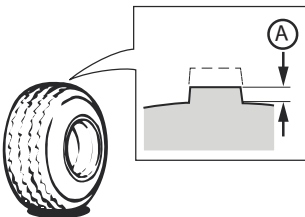

Wear Limit

Check the tyre surface for damage, cracks or embedded objects. When tire tread wears down to 1 mm (0.04 in.) see A in the diagram, replace the tyre.

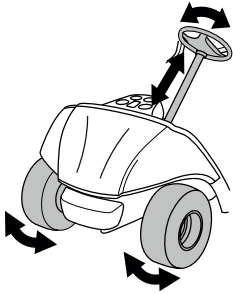

STEERING SYSTEM

Check the steering system for excessive free play by:

- moving the steering wheel up and down, and back and forth.
- turning the steering wheel slightly to the right and left.

If you feel excessive free play, or hear rattling sounds which may indicate loose steering components, consult a DRAKE dealer.

REVERSE ALARM

Check the reverse alarm by moving the drive select switch to "REV" for reverse. The alarm should sound.

PEDAL OPERATION

Check the following pedal controls for proper operation. If a pedal does not work properly, consult a DRAKE dealer.

ACCELERATOR PEDAL

⚠ WARNING

With the main switch in the "OFF" position, make sure the accelerator pedal operates smoothly.

NOTE

The vehicle may be equipped with an electromagnetic parking brake system. Please refer to the appropriate procedure for your vehicle's specification.

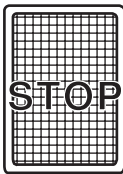
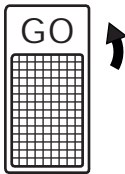
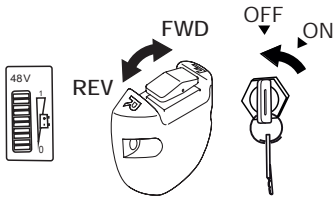

MANUAL PARKING BRAKE PEDAL

Indicated by the main brake pedal with "STOP" molded into the pedal, and the park pedal on the top left hand side as part of the brake pedal with "PARK" molded into the park pedal.

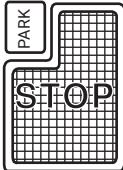

MAGNETIC PARKING BRAKE PEDAL

Indicated by a single brake pedal with "STOP" molded into the pedal and **no** park pedal on the the top left hand side of the brake pedal.



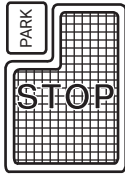

MANUAL PARKING BRAKE PEDAL

Make sure the brake pedal feels firm when pressed and returns to its original position when released.

NOTE

Disengage the parking brake by depressing the accelerator pedal or by depressing the brake pedal, and not the parking brake pedal, further.

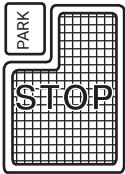
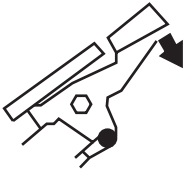

PARKING BRAKE PEDAL

Make sure the parking brake pedal locks in place with a positive click, and releases when the accelerator pedal is pressed, or the brake pedal is depressed further.

NOTE

Disengage the parking brake by depressing the accelerator pedal.

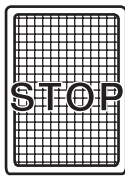

MAGNETIC PARKING BRAKE PEDAL

Make sure the brake pedal feels firm when pressed and returns to its original position when released. The magnetic brake will remain engaged.

NOTE



Whilst the main switch is "OFF" the magnetic brake will remain engaged. Depressing the accelerator pedal will not disengage the magnetic brake. See operation procedures for more information on how to disengage the magnetic parking brake whilst the main switch is "ON".

BEFORE STARTING THE VEHICLE

1. Study and understand the controls.
2. Make sure everyone is seated and holding onto the seat handles & handrails.
3. Read through the safety & information decals located on the vehicle.
4. Make sure the steering wheel is operating effectively and the wheels are in the desired direction.

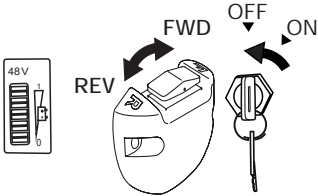

STARTING

1. With the parking brake applied, turn the drive select switch to "FWD" for forward, or "REV" for reverse. If model is equipped with a magnetic parking brake the parking brake will automatically be engaged.

CAUTION

Do not shift from "FWD" forward to "REV" reverse while the golf car is moving. Transmission damage can result.

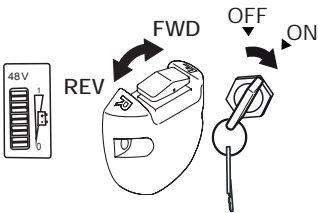

2. Turn the main switch to "ON".

WARNING

Do not depress the accelerator pedal when turning on the main switch or the golf car may start moving unexpectedly. Death or serious personal injury can result from failing to comply with the safety instructions in this manual.

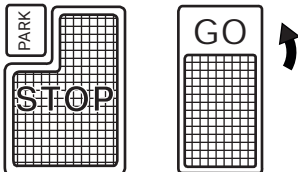

3. Check that your path is not obstructed in the direction you plan to go, and slowly depress the accelerator pedal. The golf car will start to move.

NOTE

The parking brake will automatically release when the accelerator pedal is depressed.

4.1 OPERATION PROCEDURES

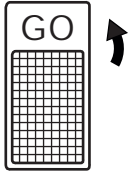

ACCELERATING

The rate of acceleration is dependant on the extent at which the accelerator is depressed. The further the accelerator pedal is depressed the faster the rate of acceleration.

NOTE

Keep one foot on either the accelerator pedal whilst accelerating or on the brake pedal whilst braking. Do not place one foot on the accelerator pedal & one foot on the brake pedal as the cart will not move for safety reasons.

⚠ WARNING

Vehicle speed must be controlled when going downhill.

Motor braking can be used to control the speed when going downhill; however steep terrain and other conditions may require pedal braking in conjunction with motor braking. Motor braking engages when the accelerator pedal is released and the cart is moving.

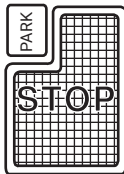
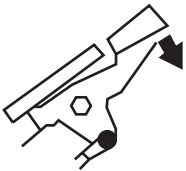

STOPPING

1. To stop the golf car, gradually press down on the brake pedal until the vehicle comes to a complete stop.

NOTE

The parking brake will automatically release when the accelerator pedal is depressed.

2. When the car has come to a stop, apply the parking brake pedal and turn the main switch to "OFF."

CAUTION

When stopped on a hill use the brake pedal to hold your position. Do not use the accelerator pedal to hold your position as this may damage the vehicle.

BATTERY CARE: LEAD-ACID BATTERIES

NOTE

Battery care instructions are specific to the battery configuration in your vehicle. Contact your nearest Drake dealer for more information on the battery configuration in your vehicle.

WARNING

Battery electrolyte is poisonous and dangerous, causing severe burns, etc. It contains sulphuric acid. Avoid contact with skin, eyes, or clothing.

Antidote:

EXTERNAL: Flush with water.

INTERNAL: Drink large quantities of water or milk. Follow with milk of magnesia, beaten egg, or vegetable oil. Call physician immediately.

EYES: Flush with water for 15 minutes and get prompt medical attention.

Batteries produce explosive gases. Keep sparks, flame, cigarettes, etc., away.

Ventilate when charging or using in an enclosed space. Always shield eyes when working near batteries.

KEEP OUT OF REACH OF CHILDREN.

EQUIPMENT NEEDED

- Goggles & chemical resistant gloves
- Distilled water
- Rubber-handled spanner
- Baking soda
- Terminal protectant

SAFETY

- Always wear protective clothing, gloves, and goggles when handling batteries.
- Do not smoke near batteries.
- Keep sparks, flames, and metal objects away from batteries.
- Use spanner with a rubber handle when making battery connections.
- The electrolyte is a solution of acid and water, so avoid skin contact.
- Check that all cable connections to the terminal are properly tightened; connections that are too tight or too loose could result in post breakage, meltdown or fire.

BATTERY CARE: LEAD-ACID BATTERIES contd.

- To avoid short circuits do not lay objects on top of battery.
- Charge batteries in a well ventilated area.
- Never add acid to a battery.

1. Terminal Protection:

- 1.1 Corrosion can build up on terminals if they are not kept clean and dry. To prevent corrosion, apply a thin coat of petroleum jelly or terminal protectant that can be purchased from your nearest Drake dealer.

2. Inspection:

- 2.1 Examine the outside appearance of the battery. The tops of the batteries and terminal connections should be clean, free of dirt and corrosion, and dry. Refer to Cleaning section 3.
- 2.2 If fluids are on the top of a lead-acid battery this may mean that the battery is being over-watered. Refer to Watering section 4.
- 2.3 Check battery cables & connection. Replace any damaged cables. Tighten any loose connections. Contact your nearest Drake dealer for assistance.

3. Cleaning:

- 3.1 Check that all vent caps are secured properly on the battery.
- 3.2 Clean the top of the battery, terminals and connections with a cloth or brush and a solution of baking soda and water (1.5Tbsp of baking soda with one cup (250ml) warm water) or store-bought battery cleaner. Do not allow cleaning solution to get inside battery.
- 3.3 Rinse with water and dry with a clean cloth.
- 3.4 Apply a thin coat of petroleum jelly or terminal protectant that can be purchased at your nearest Drake dealer.
- 3.5. Keep the area around the batteries clean and dry.

4. Watering:

Lead-acid batteries need to be watered periodically. The frequency depends on battery usage and operating temperatures. Check new batteries every few weeks to determine the watering frequency for your application. It is normal for batteries to need more watering as they age.

- 4.1 Fully charge the batteries prior to adding water. Only add **distilled water** to discharged or partially charged batteries if the plates are exposed. In this case, add just enough distilled water to cover the plates and then

BATTERY CARE: LEAD-ACID BATTERIES contd.

charge the batteries and continue with the watering procedure below.

- 4.2 Remove the vent caps and place them upside down so that dirt does not get on the underside of the cap, simply flip open the cap. Check the electrolyte level.
- 4.3 If the electrolyte level is well above the plates then it is not necessary to add more distilled water.
- 4.4 If the electrolyte level is barely covering the plates, add distilled or de-ionized water to a level 1/8" (3 mm) below the vent well (this is the plastic shield inside the vent hole) for standard batteries.
- 4.5 After adding water, secure vent caps back on batteries.

⚠ WARNING

A lead-acid battery should never be fully discharged.

Lead-acid batteries can only be discharged down to 50% remaining capacity before irreversible damage occurs. In practice this means that you will only be able to use half of your battery capacity per charge & discharge cycle.

CAUTION

Do not overfill batteries. The charging cycle will expel electrolyte and result in component damage.

⚠ WARNING

Lead-acid batteries contain lead (Pb), other metals, acids and other compounds. If improperly handled, they can contaminate both water and soil, causing environmental damage and personal injury.

Please contact your nearest Drake dealer for more information on how to properly dispose of your batteries.



5 MAINTENANCE

BATTERY CARE contd.

How to use a hydrometer. Check the specific gravity of the battery fluid in each cell against the readings on the chart below. Consult a DRAKE dealer if any low readings are found, or if readings vary more than one point between cells.

Temperature		Satisfactory Uncorrected Hydrometer Reading
°C	°F	
48.9	120	1.244
43.3	110	1.248
37.8	100	1.252
32.2	90	1.256
26.7	80	1.260
21.1	70	1.264
15.6	60	1.268
10.0	50	1.272
4.4	40	1.276
-1.1	30	1.280

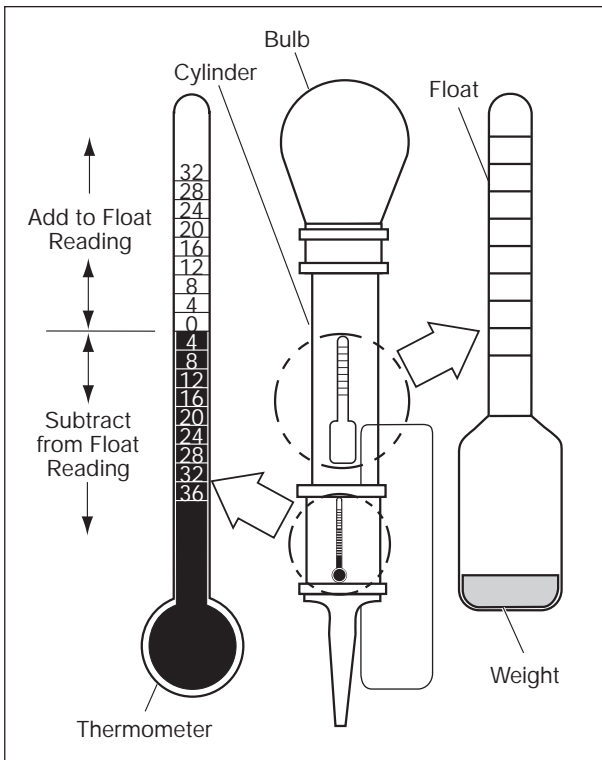

BATTERY CARE: LITHIUM BATTERY

Manufacturer: RoyPow Technology

NOTE

The battery is equipped with an integrated cell management system which features:

- Cell balancing
- Battery voltage monitoring
- Battery current monitoring
- Pre-warning when battery capacity reaches less than 20%
- Battery temperature monitoring (integrated temperature sensor)

⚠ WARNING

1. Do not disassemble, reassemble, or repair the battery. Incorrect reassembly may cause combustion or electric shock.
2. Do not short-circuit the battery, use it near heat or water sources, or allow it to become wet.
3. Do not use the battery if badly damaged or operate it with damaged cables or charging adaptors.
4. Do not operate this product in explosive atmospheres (i.e. flammable liquids, gases or dust).
5. Do not permit the battery to freeze. Never charge a frozen battery.
6. In case of skin or eye contact with any of the chemicals within the battery, rinse immediately with clean water and seek medical attention immediately.
7. A LiFePO₄ lithium battery should never be fully discharged.
8. LiFePO₄ lithium batteries can only be discharged down to 20% remaining capacity before irreversible damage occurs. In practice this means that you will only be able to use 80% of your battery capacity per charge & discharge cycle.

NOTE

Lithium-ion batteries are recyclable. If you have any questions regarding battery disposal or recycling, please consult your nearest Drake dealer.

Li-ion

5 MAINTENANCE

BATTERY CHARGING

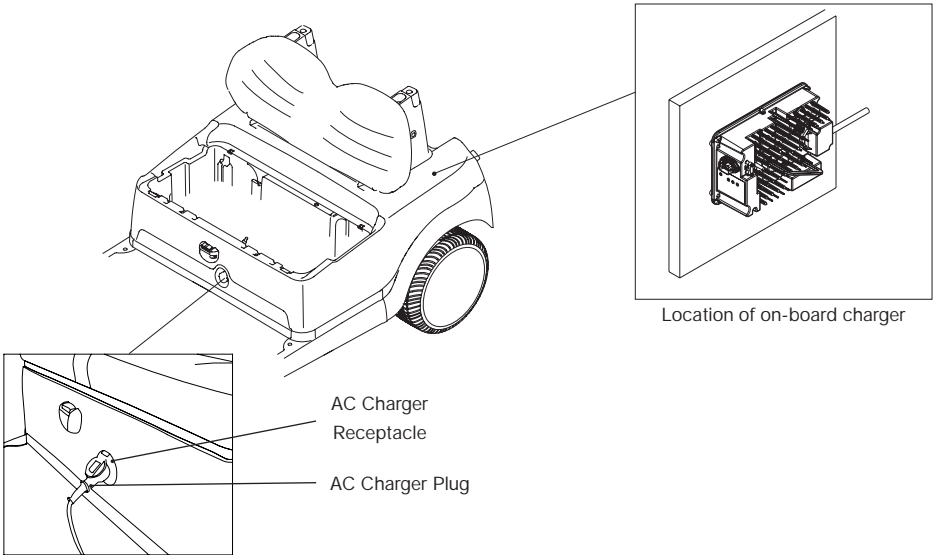

The cart is equipped with an on-board charger. It's location is illustrated above.

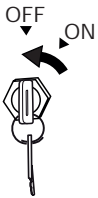

Charging the Cart:

1. Ensure that the cart is turned off by the main switch.
2. With the AC charger plug disconnected from the AC outlet, connect the AC charger plug to the AC charger receptacle.
3. Connect the power plug of the AC charger plug to an appropriate live AC outlet. Indicated by the blue "AC PRESENT" LED turning on.
4. The charger will start automatically indicated by the yellow "CHARGE STATUS" LED beginning to blink slowly.
5. If the charger is fitted with a RoyPow lithium battery, the LED voltage indicator on the dashboard will begin to cycle from current state of charge to full.
6. If the AC charger plug must be removed from the AC charger receptacle whilst a charge cycle is in progress, disconnect the AC power plug from the AC outlet before removing the AC charger plug from the AC charger receptacle.
7. The charge cycle 80% point is indicated by the yellow LED beginning to blink slowly.



BATTERY CHARGING

8. The charger automatically terminates the charge cycle when a battery reaches full charge, which is indicated by [1] the solid illumination of the green LED or [2] the green LED beginning to blink slowly indicating a post-charge phase. The required charge time is affected by numerous factors, including battery amp-hour capacity, depth of discharge, battery temperature, and battery age/usage.
9. Before operating the cart, disconnect the AC charger plug from the AC charger receptacle.

Lead-Acid:

The battery charger is designed to fully charge the battery set. If the batteries are severely deep cycled, some automatic battery chargers contain an electronic module that may not activate and the battery charger will not function.

Before charging please ensure the electrolyte level in all cells are at the recommended level and cover the plates.

Storage Mode (Lead-Acid only):

1. Storage mode is an automatic function on the charger designed to keep your battery maintained during storage periods that last a few weeks to several months at a time. Maintain AC power to the charger after the charge cycle completes to initiate storage mode.
2. Do NOT disconnect the AC charger plug from the AC charger receptacle until the cart is needed for use. Disconnecting or reconnecting the AC power to the charger may start a charge cycle, but disconnection disrupts the storage mode so optimum battery maintenance is not achieved.
3. After several months of storage your batteries should be serviced and cycled and the charger reset by disconnecting AC power to the charger for a minimum of 10 minutes before continuing another storage season.

LiFePO4 Lithium:

The battery charger is designed to fully charge the battery set. Once the charge cycle is completed, remove the cart from charge when convenient. Do not leave the cart on charge.

WARNING

Do not disconnect the DC output cord from the DC charger receptacle when the charger is on or an arc could occur that may cause an explosion.

BATTERY CHARGING

Storage Mode (LiFePO4 lithium only):

1. Do NOT maintain AC power to the charger for extended periods of time. It is recommended to remove the AC power from the charger, as soon as is convenient, once charge cycle has been completed.
2. If the cart will be left idle & unused for 5 or more days, charge the cart to full capacity, and turn off the battery main switch to put the battery into storage mode.
3. Ensure the cart is in dry and well ventilated room that is between 0°C and 35°C.
4. Do not store the cart near corrosive material, fire, or heat sources.
5. For periods of long-term storage up to 6 months, complete a full charge cycle, turn off the battery at the main switch, and avoid over-discharge by keeping the SOC above a minimum 20%.

WARNING

Do not disconnect the DC output cord from the DC charger receptacle when the charger is on or an arc could occur that may cause an explosion.

Bluetooth Wireless:

The charger features Bluetooth wireless communication, which can be accessed using an Apple® or Android™ smart phone, tablet, or similar device. Download the ChargerConnect app for your device by scanning the QR code on the charger or visiting the App Store® or the Google Play™ store and searching for “ChargerConnect” by Lester Electrical.

The charger communication electronics are DC powered, so the charger must be connected to a valid battery pack in order to communicate with it via Bluetooth. If the charger is connected to a valid battery pack, open the ChargerConnect app and select the charger from the list of available units the app is able to communicate with. The charger serial number is the identifier of the unit, unless the “Charger ID” has been previously changed via the app. While connected, the Red, Yellow, and Green LEDs on the charger will slowly blink at the same time until the Bluetooth communication is disconnected from the charger.



Application Icon

BATTERY INSTALLATION

Use care to connect the battery wires as shown below. Carefully place battery cables and holddowns making sure that cables do not lay across vent caps. Always remove the negative (-) cable to the motor controller first, and install it last. Tighten the battery post hardware to 50 - 70 in. lbs. (6 - 8 Nm) torque. Protect the battery terminals and battery wire terminals with a commercially available protective coating.

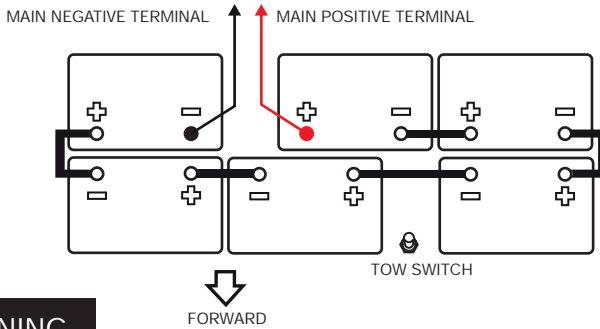

⚠ WARNING

When working with batteries, do not put wrenches or other metal objects across the battery terminals. An arc can occur causing an explosion or fire at the battery. Always remove the negative (-) cable to the motor controller first, and install it last. A spark can occur causing an explosion or fire at the battery.

Before installing or uninstalling any battery connections, ensure the main switch is turned off. Use care to connect the battery wires as shown below. Tighten the battery post hardware to 5 Nm torque. Do NOT overtighten as this may damage the battery post. Use M8 bolts as provided.

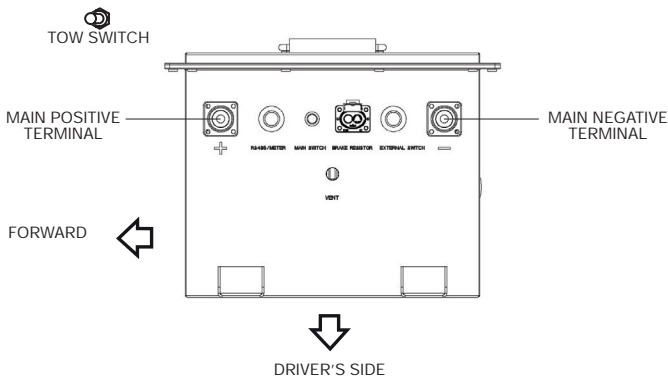

5 MAINTENANCE

TRANSAXLE OIL

The only maintenance required for the first five years is the periodic inspection of the lubricant level. The rear axle is provided with a lubricant level check/fill plug located on the bottom of the differential. Unless leakage is evident, the lubricant need only be replaced after five years.

Replacing the lubricant:

- place the car on a flat, level surface
- lift the cushion
- clear the area around the oil plug
- remove the oil plug
- If required add SAE 90 gear box oil until it is level with the plug opening
- replace the oil plug

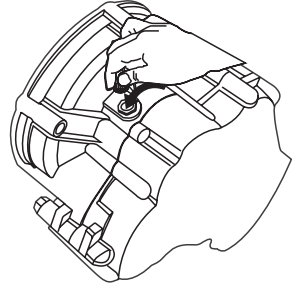

CAUTION

Do not allow foreign material to enter the transaxle. Serious transaxle damage can result.

WHEEL REPLACEMENT

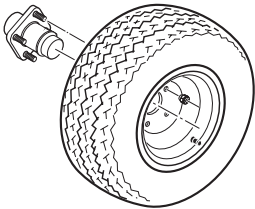

Tyre style may vary

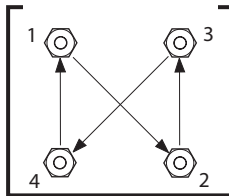

"Cross Sequence"

To remove and install a wheel on your golf car:

1. Block the wheels to prevent the golf car from moving, loosen the lug nuts.
2. Elevate the golf car with a jack and remove the lug nuts and the wheel.
3. Reverse the removal steps when installing the wheel using the "cross sequence" when tightening the lug nuts.
4. Wheel nut tightening torque: 80 Nm, 8.0 m.kg (58 ft.lb)

⚠ WARNING

Before performing wheel or brake maintenance, verify that the main switch is in the "OFF" position. Accidental starting of the vehicle could cause the vehicle to move, causing death or serious personal injury.

BRAKE ADJUSTMENT

The brakes on your golf car are self-adjusting. Before you operate the golf car, press down on the brake pedal several times to make sure the brakes are functioning properly.

WARNING

Consult your DRAKE dealer before using your golf car if you suspect any brake problems. Brake failure could result in a serious accident. Death or serious personal injury can result from failing to comply with the safety instructions in this manual.

BRAKE PEDAL FREE PLAY ADJUSTMENT

Check the brake pedal free play by pressing against the pedal with two fingers (using light force) and measuring the distance the pedal travels before resistance is felt.



To adjust the brake pedal free play:

1. Remove the floor mat and service lid from the floor of the golf car.
2. If the free play distance needs adjusting, loosen the lock nut and turn the adjusting nut in or out until free play specification is met. Then tighten the lock nut in place.
3. Brake pedal free play movement should be 20 – 30mm.

WARNING

Over-tightening the brake cables will increase brake wear and affect overall performance of the braking function. Premature brake wear can result. Death or serious personal injury can result from failing to comply with the warning labels in this manual.

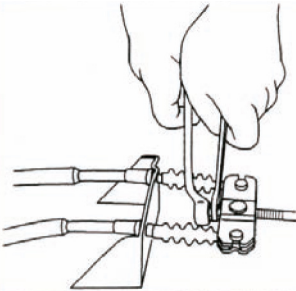

MANUALLY DISENGAGING THE MAGNETIC PARKING BRAKE

 WARNING

Once the magnetic parking brake is manually disengaged the cart will roll freely and may cause injury or death. Place wheel blocks on the rear wheels before manually disengaging the magnetic parking brake.

The magnetic parking brake engages automatically. If the cart is stationary and cannot be driven, it may be required to manually disengage the magnetic parking brake to tow or roll the cart. There are two ways to manually disengage the magnetic parking brake:

1. Within the battery bay there is a two-way plug with two wires connecting to both the main positive terminal and main negative terminal of the battery pack supplying the nominal voltage of the battery pack. Within the battery bay there is another two-way plug with connections running through the harness to the magnetic parking brake. These cables are marked "EM brake". Connect these two plugs together to supply direct voltage and current to the magnetic parking brake to manually disengage parking brake. To reengage the magnetic parking brake again, disconnect the two plugs labelled "EM brake".
2. If the power supply from the battery pack is not available, you will need to manually disengage the magnetic parking brake by inserting 2x M5*30mm allen bolts into the holes on the magnetic parking brake on the side of the motor as indicated in the diagram below. Whilst the bolts are inserted the magnetic parking brake will be disengaged and the cart will roll freely. To reengage the magnetic parking brake, completely remove the 2x M5*30mm allen bolts from the magnetic parking brake on the side of the motor.

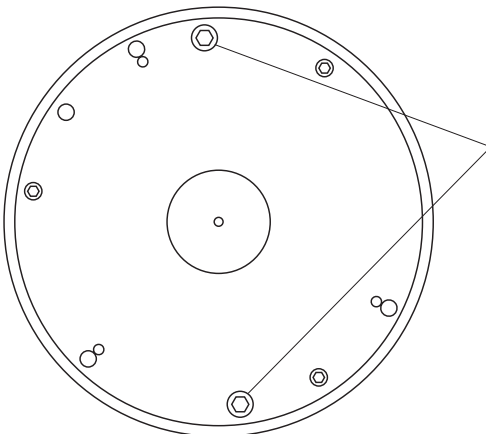

Insert each M5*30mm allen bolt in the holes as indicated.

TOWING

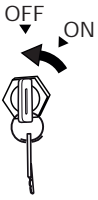

NEUTRAL

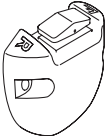

WARNING

- Do not tow the cart on public streets or highways.
- Use only approved & certified tow bars.
- Turn the key switch to OFF and place the Forward/Reverse switch in the NEUTRAL position before towing the cart.
- Release the manual parking brake. If the cart is equipped with a magnetic parking brake, it will be required to manually disengage the magnetic parking brake using one of the two methods described in the page “manually disengaging the magnetic parking brake” in the maintenance section.
- Place the Tow/Run switch to the TOW position; otherwise, the cart will not roll while being towed.
- Extreme caution should be used when towing any cart.
- Do not exceed 8 km/h towing speed.
- Avoid sudden starts, sudden stops, and tight turns when towing.
- Avoid stopping on a hill when towing. If you must stop on a hill, avoid sudden starts or rolling backwards and stopping suddenly. Failure to heed this warning could cause the vehicle to overturn, possibly resulting in severe personal injury.
- Stay clear from the area between the tow vehicle and the towed cart or trailer.

TRANSPORTATION ON A TRAILER



NEUTRAL



OFF | ON

TOW  RUN
 **WARNING**

- For use on public roads, the trailer must meet all national and provincial requirements regarding tail lights, brake lights, etc.
- Do not tow a Drake cart behind a passenger vehicle or truck on a public road unless it is on an approved & certified trailer.
- The cart to be towed should be tied securely to the trailer, with the Forward/Reverse switch in the NEUTRAL position, the key switch in the OFF position, and the parking brake firmly pressed and locked or the magnetic parking brake engaged to prevent free movement of the cart.
- Do not allow people in the trailer or vehicle being towed.
- Avoid sudden starts, sudden stops, and tight turns when towing.
- Avoid stopping on a hill when towing. If you must stop on a hill, avoid sudden starts or rolling backwards and stopping suddenly. Failure to heed this warning could cause the vehicle to overturn, possibly resulting in severe personal injury.
- When towing on a trailer, normal road speed of the tow vehicle should be reduced.
- Because of the added length of the trailer, use caution when making turns.
- The cart must be forward facing to prevent any damage to the windshield or windshield retain clips and secure the seat bottom before transporting the cart on a trailer.
- Stay clear from the area between the tow vehicle and the towed vehicle or trailer.

MAINTENANCE CHARTS

Regular maintenance is required to ensure the best performance and safe operation of your golf car.

WARNING

Turn off the main switch and apply the parking brake when you perform maintenance, unless otherwise specified. If you're not familiar with servicing the machine, death or serious personal injury can result. When in doubt the work should be done by a Drake dealer or other qualified mechanic.

CS – CHECK CA – CHECK & ADJUST R – REPLACE S – SERVICE CL – CLEAN & LUBRICATE L – LUBRICATE

	Remarks	Pre-Op	40 rounds 20 hours 160 kms (Every month)	250 rounds 125 hrs 1000 kms (Every 6 months)	500 rounds 250 hrs 2000 kms (Every year)	1000 rounds 500 hrs 4 000 kms (Every 2 years)	2000 rounds 1000 hrs 8 000 kms (Every 4 years)
PRE-OP	Charge	S	S	S	S	S	S
	Clean battery tops, check hold-down screws and terminals are tight	S	S	S	S	S	S
	Check brake pedal free play and adjust if necessary	CS	CA	CA	CA	CA	CA
	Check steering operation	CS	CS	CS	CS	CS	CS
	Check tyre pressure, tread depth and tyre surface for damage	CS	CA	CA	CA	CA	CA
	Check body and chassis for damage	CS	CS	CS	CS	CS	CS
	Check tightness of all bolts, nuts, screws and rivets	CS	CS	CS	CS	CS	CS
Check reverse alarm operation	CS	CS	CS	CS	CS	CS	
EVERY MONTH	Check electrolyte level		CS	CS	CS	CS	CS
	Check for loose or broken connections		CS	CS	CS	CS	CS
	Clean/lube pedal control area		CL				
EVERY 6 MONTHS	Check all wire insulation for cracks and/or worn spots			CS	CS	CS	CS
	Check shock absorbers for oil leaks and damaged springs			CS	CS	CS	CS
EVERY 12 MONTHS	Perform a discharge test				S	S	S
	Apply Terminal protectant				S	S	S
	Check rear axle bearing play for roughness or freeplay				CS	CS	CS
	Check Steering knuckle bushing free play / Adjust wheel alignment				CA	CA	CA
	Check wheel nut tightness front wheel front wheel bearing play				CS	CS	CS
	Check transaxle oil level and inspect for leakage				CS	CS	CS
	Check pedal stop operation and adjust if necessary				CA	CA	CA
EVERY 4 YEARS	Replace transaxle oil						R
	Inspect brake shoes and adjust or replace if necessary						CA

Perform the following preparations when not using your golf car for extended periods of time:

NOTE

Turn the main switch key to the "OFF" position, lift the seat and move the tow switch into the "TOW" position. Remove the key from main key switch, and store key in a safe place.

BATTERY PREPARATION

Recharge the batteries and check the fluid level every 60-90 days to keep them fully charged.

In cases of long storage periods, disconnect the cables.

Clean the top of lead acid batteries with a solution of baking soda and water, if necessary, to remove corrosion.

CAUTION

- Do not allow cleaning solution to enter battery cells. Serious battery damage can result.
- Do not attempt to charge frozen batteries or batteries with bulged cases. Discard the battery. Frozen batteries can explode.
- Batteries in a low state of charge will freeze at low temperatures.
- To avoid exposing electrical components to moisture and subsequent damages, do not use any type of pressure washing or steam cleaning equipment to wash the vehicle.

CHASSIS PREPARATION

Verify that the air pressure in the tyre is 25psi or 172 kPa or 1.5 bar.

Clean exterior of the golf car and apply a rust inhibitor where necessary.

Cover the vehicle and store it in a dry, well-ventilated place.

8 LIMITED WARRANTY

DRAKE LIMITED WARRANTY FOR CX VEHICLES

Drake Golf Carts CC "DRAKE" hereby warrants that any new (non-fleet) cx model year 2022 or more recent, identified by the prefix "cx" in the model name "Vehicle", and sold by DRAKE or an authorised Dealer or Distributor in South Africa, will be free from defects in material and workmanship subject to normal use and service for the periods stated below "Limited Warranty".

This Limited Warranty covers the material & workmanship on the components listed below, based on the period of warranty specified below. Any component adjudged to be defective due to either faulty workmanship or materials, as determined by DRAKE, will be replaced by DRAKE or an authorised Dealer or Distributor. Removal, repair or reinstallation of the defective component(s) shall be performed only by DRAKE, it's authorised Dealers or Distributors, or a service agency approved by DRAKE. For removal, repairs and reinstallation of components by a qualified technician other than DRAKE's factory technicians or an authorised Dealer or Distributor, DRAKE will provide only the replacement parts or components.

The purchaser must provide the proof of the date of purchase such as an original tax invoice "Sales Receipt" with any warranty claim. Parts repaired or replaced under this Limited Warranty are warranted for the remainder of the length of the original Warranty Period. This Limited Warranty applies to the Vehicle regardless of the owner, and any subsequent change of ownership, that may arise during the warranty period. The original or subsequent owner is requested to present the initial Sales Receipt from DRAKE or the authorised Dealer or Distributor from which the Vehicle was originally purchased.

Component	Period
Main Frame	3 years
Electric Drivetrain: Transaxle & Motor	3 years
Major Electronics: Speed controller & Battery charger	2 years
Suspension: Steering rack, shocks, steering column, leaf springs	1 year
Deep Cycle Battery**	1 year
Lithium LiFePO4 Battery* "Lithium Battery"	5 years
All other parts & components	3 years

*The Lithium Battery is warranted under separate conditions & limitations (See details below)

** The Deep Cycle Battery is not warranted by DRAKE.

EXCLUSIONS:

Specific exclusions from this Limited Warranty:

- Ordinary wear & tear, routine maintenance parts, and damage to electrical components due to fluctuations in electrical current.
- Fading, rust, failure or deterioration due to exposure to the elements.
- Abnormal or unintended strain or use, neglect, accident or collision, improper maintenance or improper installation of accessories and installation of parts and accessories that are not DRAKE original parts and accessories.
- Non-approved alterations or modifications that alter the suspension, the weight distribution or balance of the cart.
- Acts of God or nature, including but not limited to lightning, hail damage, flooding and fire.
- Damage or loss resulting from vandalism, theft, war or other events in which DRAKE has no control.

EXCLUSIONS CONTINUED.:

- Warranty repairs made by a non-authorized service agency that is neither DRAKE nor an authorized dealer or distributor.- Any and all expenses incurred in transporting the vehicle to and from DRAKE or an authorized dealer or distributor for the purpose of fulfilling a warranty claim or service.
- Any and all expenses, fees or duties incurred relative to inbound freight, importation, or customs.
- Damaged charger plug, and/or resultant damage as the charger plug is a wear and tear item subject to abuse
- Battery damage due to improper charging practices or a defective charger
- The Deep Cycle batteries are held under a separate warranty and is not warranted in this Limited Warranty

THIS LIMITED WARRANTY MAY BE VOIDED OR LIMITED AT THE SOLE DISCRETION OF DRAKE IF THE VEHICLE:

- shows indications that the cart modified by an unauthorized service agent including but not limited to the controller's parameters relating to speed, acceleration and/or braking, the mechanical braking system, the steering system, the transaxle and other systems of the vehicle that may cause it to perform in a manner not intended by DRAKE or not within DRAKE's specifications.
- shows indications that routine or necessary maintenance was not performed as detailed within the Owner's Manual, or within the time or manner specified within the Owner's Manual.
- has electrical accessories not manufactured or sold by DRAKE for the normal functioning of the Vehicle or for external accessories which are energy consuming devices that would draw current directly from the battery pack.
- shows indications that the battery pack was opened, disassembled or tampered with in any way
- shows indications that attempts may have been made to intentionally reduce the life of the battery pack
- consists of batteries not approved by DRAKE

NO CONSEQUENTIAL DAMAGES

DRAKE will not under any circumstances be liable for any indirect, incidental or consequential damages including but not limited to, death, personal injury, property damage arising from or related to any alleged failure in a vehicle or battery charger, or any damage or loss to the purchaser or third party for loss of use, loss of time, inconvenience, or any other economic loss, whether or not DRAKE was apprised of the foreseeability of such damage or losses. Any legal claim or action arising that alleges breach of warranty must be brought within ninety (90) days from the date the warranty claim arises

The Limited Warranty for all parts and components of the Vehicle other than the batteries shall commence on the date of delivery to the purchaser or the date on which the Vehicle is placed in storage as requested by the purchaser. The warranty for Lithium Batteries shall commence on the earliest of the following dates:

- (a) of Vehicle delivery to the Purchaser,
- (b) on which the Vehicle is placed in storage as requested by the purchaser or
- (c) ninety (90) days from the date of sale or lease of the Vehicle by "DRAKE" to an authorized Dealer or Distributor.

Parts repaired or replaced under this limited warranty are warranted for the remainder of the length of the original warranty period. This Limited Warranty applies to the original purchaser and any subsequent owners of the cart, however the Sales Receipt with the original date of purchase from DRAKE or the authorized Dealer or Distributor is required when making a warranty claim with the warranty department.

LITHIUM BATTERY LIMITED WARRANTY

Lithium Battery			
Amperage	56ah	105ah	160ah
Years	5 Years	5 Years	5 Years
Limitation	Rated end of life	Rated end of life	Rated end of life

Lithium Battery Warranty Limitations, Conditions and Exceptions:

The warranty on the Lithium Battery is a pro-rata, return-to-base warranty "Pro-Rata Warranty" fulfilled not by "DRAKE" but RoyPow Technology Company Limited "the Manufacturer" of the lithium batteries. Under the Pro-Rata Warranty the manufacturer will repair, replace, or refund (subject to the limits explained below), at its own discretion, any Product deemed to be faulty under the terms of the Pro-Rata Warranty. Any replacement product supplied by the Manufacturer will consist for the remainder of the warranty period.

Exclusions:

This warranty is void if the Lithium Battery has been:

- Stored, installed, used or charged in any manner that is contrary to the Manufacturer's instructions or data sheets or generally accepted good industry practice
- Opened, modified or tampered with in any way, including the alteration or erasure of date codes etc
- Used for an application or in a manner for which they were not designed
- Stolen or at any time outside of the customer's control (except in the normal course of business)
- Subjected either during storage or use to extreme environmental conditions, including heat, cold and moisture, out with the limits defined in the Manufacturer's instructions and data sheets

Warranty claims on the Lithium Battery require specific testing and analysis prior to approving any such warranty claim. Contact DRAKE or the authorised distributor or dealer from whom the vehicle was purchased when making your warranty claim. It will be required that the vehicle, or in particular circumstances, the battery be taken to DRAKE, an authorised Dealer or Distributor or an authorised service agent nearest your location.

Storage & Operation Limitations	Time Allowed
Storage between charge cycles in normative conditions (0°C ~ 35°C)	6 months
Storage in extreme conditions (-20°C ~ 45°C)	1 month
Discharge cycling (less than -20°C or greater than 55°C)	Not Allowed
Charge cycling (less than 0°C or greater than 55°C)	Not Allowed

All consequential losses and/or damages arising from the malfunction of the Lithium Battery are expressly excluded.

The cost of transporting a Lithium Battery or it's relevant parts that is the subject of a warranty claim, or is being supplied by the Manufacturer in recompense for a Warranty claim, from the purchaser or DRAKE or an authorised Dealer or Distributor to the Manufacturer or from the Manufacturer to the purchaser or DRAKE or an authorised Dealer or Distributor is excluded and is the responsibility of the purchaser or DRAKE or an authorised Dealer or Distributor.

Limitations:

The value of any Warranty claim, whether recompensed in replacement goods, services or money, will be based on the price paid when the goods were originally purchased from the Manufacturer. Any replacement supplied in recompense will be the nearest equivalent that is available to the Lithium Battery in the Pro-Rata Warranty claim.

This is a Pro-Rata Warranty. This means that in the event that the Manufacturer upholds a claim under the terms of this Pro-Rata Warranty any recompense will take into account the number of months that have elapsed from the warranty Commencement Date to the date when the Manufacturer was first notified of the claim. The value of any recompense due will reduce by $100/(12 \times \text{Warranty duration in years})\%$ of the original purchase price from the Manufacturer per month from the date of commencement of the Pro-Rata Warranty to the date when the Manufacturer was first notified of the Pro-Rata Warranty claim. In the case of a product with a 5 year warranty the monthly reduction is 1.67% of the original purchase price; in the case of a 1 year warranty the monthly reduction is 8.33%.

Purchaser's Responsibility under this Limited Warranty shall be to:

- operate and maintain the Vehicle and battery charger as specified in the Owner's Manual.
- contact DRAKE or an authorised Dealer or Distributor with regards to any queries which may not be clear to the purchaser in the Owner's Manual.
- make DRAKE or an authorised Dealer or Distributor aware of any Warranty Claim within ninety (90) days in which the defect was discovered.

DRAKE MAKES NO OTHER WARRANTY, EXPRESS OR IMPLIED. ALL IMPLIED WARRANTIES OF MERCHANTABILITY AND FITNESS FOR A PARTICULAR PURPOSE WHICH EXCEED THE OBLIGATION AND TIME LIMITS STATED IN THIS WARRANTY ARE HEREBY DISCLAIMED BY DRAKE AND EXCLUDED FROM THIS WARRANTY.



Drake Golf Carts CC
Address: 1 Estee Ackerman Street, Jet Park, Boksburg,
1459
Website: www.drakegolfcarts.co.za
Tel: 060 540 6277
Cell: 064 959 4070
Email: info@drakegolfcarts.co.za

This manual may not be reproduced in any way,
whole or in part, without the express permission of
DRAKE GOLF CARTS Company.